

深圳市能点科技有限公司

SHENZHEN EPT TECHNOLOGY CO., LTD.

规格书
SPECIFICATION



D2CS-H

电容式液位传感器

Capacitive Liquid Level Sensor



版本 Version: D

日期 Date: 2021/03/17

www.eptsz.com

www.eptsensor.com

目录页/Table of Content

1. 修订记录/Revision History
2. 应用领域/Application
3. 产品特征/General Features
4. 电气参数特性/Electrical Specification
5. 推荐应用电路/Recommended Application Circuit
6. 包装/ Package
7. 尺寸和推荐安装/Outline Drawing and Recommended Installation



本规格书为相应产品作业之标准，在客户确认后，会作为生产、供货的依据。如有特殊要求，可告知联系你的市场部人员，并出具承认书。

This specification is the standard for the operation of the corresponding products. It will be used as the basis for production and supply after confirmation by the customer. If you have special requirements, please contact our sales and issue an acknowledgement.

1. 修订记录/Revision History

No.	日期/Date	备注/Remark	修订/Revision
1	20170518	初始规格书版本发行/ MP Version issue	A
2	20181030	结构细节修改/ Structural details modification	B
3	20200619	细节修改/ Details modification	C
4	20210317	规格书更新/Specification update	D



本规格书为相应产品作业之标准，在客户确认后，会作为生产、供货的依据。如有特殊要求，可告知联系你的市场部人员，并出具承认书。
This specification is the standard for the operation of the corresponding products. It will be used as the basis for production and supply after confirmation by the customer. If you have special requirements, please contact our sales and issue an acknowledgement.

2. 应用领域/Application

饮水机/ Water dispenser

咖啡机/Coffee machine

医疗设备/Medical devices or equipment

需要侦测液体的电器，设备等/Electrical equipment and devices which need to detect liquid

3. 产品特征/Product Features

无机械运动部件、可靠性高

No mechanical moving components and with high reliability

只需贴于容器外壁即可使用，非常方便安装

Simply locate the sensor to outside the liquid container (low temp) for detection. Easy assembly.

超低待机功耗

Low Power Consumption

防水等级 IP64

Waterproofing standard IP64

支持检测厚度≤6MM，依据厚度定制软件

Support the detection of thickness ≤ 6MM, the software can be determined according to the actual thickness

4. 电气参数特性/ Electrical Specification (Ta=25°C)

参数/Parameter		符号 /Symbol	条件/Condition	最小值/Min	典型/Typ	最大值/Max	单位/Units
直流特性	工作电压/Working Voltage	VDD	—	4.5	5	24	V
	电流/Current (空载)	IDD	VDD=5V 有水状态/in Water	—	—	<12	mA
			VDD=5V 无水状态/in Air	—	—	<12	mA
输出特性 Output characteristic	输出信号类型/Output Signal		TTL	—	—	—	—
	有水状态输出电压/Output Voltage in Water	VO1	VDD=5V Ta=25°C	—	—	<0.3	V
	无水状态输出电压/Output Voltage in Air	VO2	VDD=5V Ta=25°C	>4.5	—	<5.3	V
	输出源电流/Output Current	IOL	VDD=5V Ta=25°C	—	—	<10	mA
	响应时间/Response Time		VDD=5V Ta=25°C	—	—	1	S
极限值 Limit value	工作温度/Operating Temperature	Topr	VDD=5V	0	—	40	°C
	储存温度/Storage Temperature	Tstg	—	-20	—	60	°C
	工作寿命/Working Time	Wt	VDD=5V Totg=25°C	—	50000	—	h



本规格书为相应产品作业之标准，在客户确认后，会作为生产、供货的依据。如有特殊要求，可告知联系你的市场部人员，并出具承诺书。

This specification is the standard for the operation of the corresponding products. It will be used as the basis for production and supply after confirmation by the customer. If you have special requirements, please contact our sales and issue an acknowledgement.

5. 推荐应用电路/Recommended Application Circuit

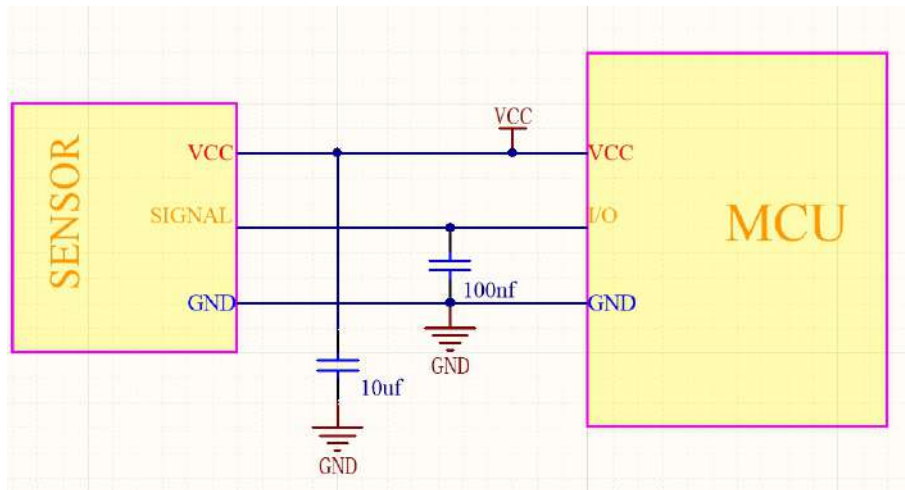

6. 应用及检测/Application & Detection

1) 侦测液位的判定标准, 依据客户水箱结构, 厚度, 作为判定标准;

Criterion of detecting liquid level depends on the structure and thickness of clients' water tank;

2) 侦测到有液体时, 传感器输出低电压, 输出电压 $<0.1V$;

When detected liquid, the sensor will output $<0.1V$ low voltage;

3) 侦测到无液体时, 传感器输出高电压, 输出电压 $>VCC-0.1V$;

When detected no liquid, the sensor will output $>VCC-0.1V$ high voltage;

注意事项/Notice:

4) 传感器不能检测金属器件.

The sensor can't be used near metal.

5) 传感器不能放置于潮湿的环境中

The sensor cannot be placed in a humid environment.

7. 包装/ Package

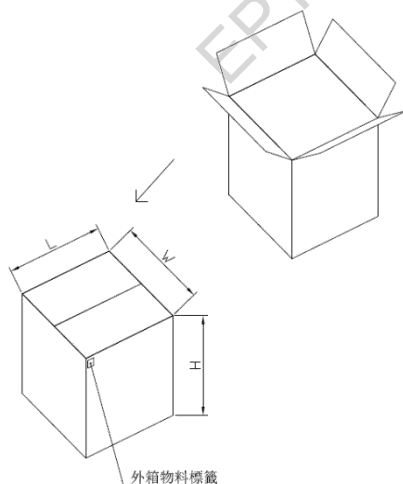

说明:

1. 外箱尺寸: 34X27.5X33.5 CM

1箱产品数量: 800 PCS

2. 包装盒尺寸: 33.5X13.5X8 CM

1盒产品数量: 100 PCS

Description:

1. Carton size: 34X27.5X33.5 CM

Quantity/ctn: 800 PCS

2. Packing box size: 33.5X13.5X8 CM

Quantity/box: 100 PCS

8. 尺寸和推荐安装/Outline Drawing and Recommended Installation



本规格书为相应产品作业之标准, 在客户确认后, 会作为生产、供货的依据。如有特殊要求, 可告知联系你的市场部人员, 并出具承认书。

This specification is the standard for the operation of the corresponding products. It will be used as the basis for production and supply after confirmation by the customer. If you have special requirements, please contact our sales and issue an acknowledgement.

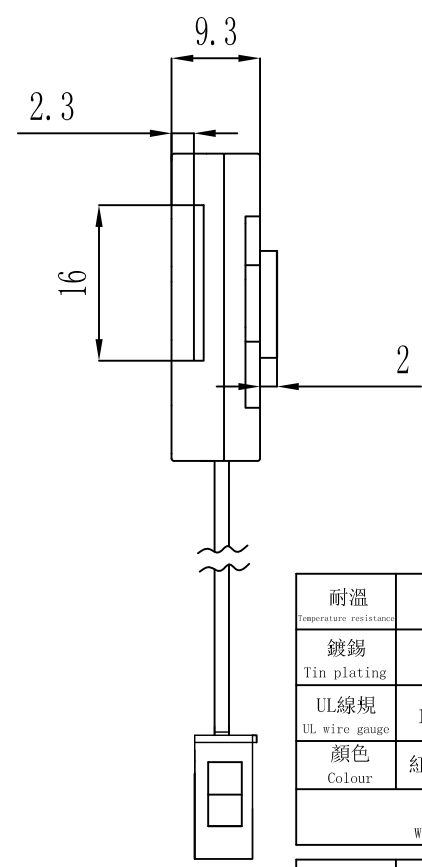
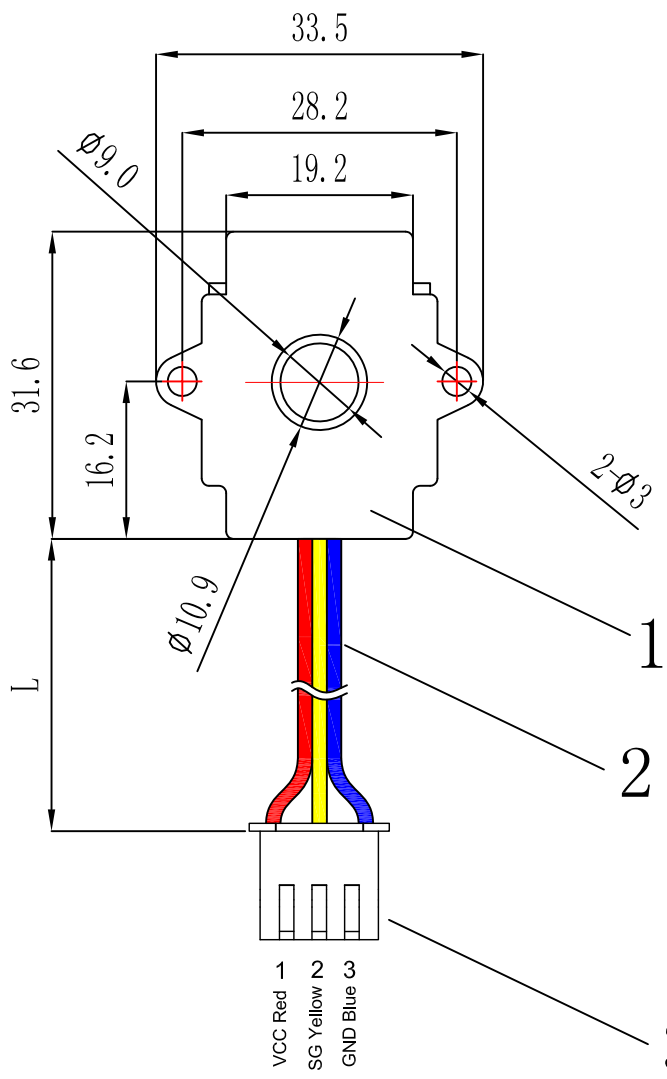
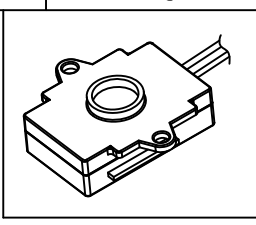
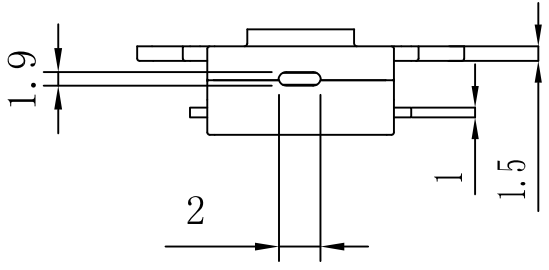

耐溫 Temperature resistance	80°	耐壓 Withstand voltage	300V
鍍錫 Tin plating		長度 Length	400±20
UL線規 UL wire gauge	1007	UL編號 UL number	E348531
顏色 Colour	紅黃藍	線號 Line number	26AWG

線材規格
Wire specification

脚距 Foot distance	2.54	孔數 Number of holes	3
顏色 Colour	White	型號 Model	XH

端子規格
Terminal Specifications

3	端子 Terminal	1	
2	線材 Wire	1	
1	感測器主體 Sensor body	1	
編號 NO.	名稱 Name	數量 QTY	備註 P.S.

設計 Designer	Chen	材料 Material	*	單位 Unit	mm
檢查 Checked	Chen	表面處理 Finish	*	比例 Scale	*
審批 Approver	Wei	數量 Quantity	*	篇幅 Size	A4
一般公差 Tolerances	0-10	±0.10	0.8	備註 Remarks	*
	10-35	±0.15		視圖 View	
	35-70	±0.20			



能點科技有限公司
EPT technology co., LTD

產品名 Product Name	D2CS-H	日期 Date	21-03-10
頁面內容 Page content	產品圖	版本 REV	D
圖號 DWG NO.	*	頁數 Pages NO.	1/2

1 2 3 4 5 6

A

A

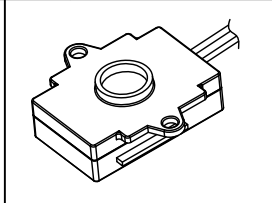

B

B

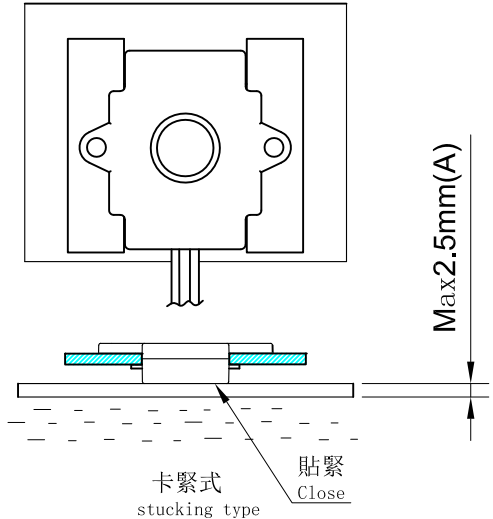
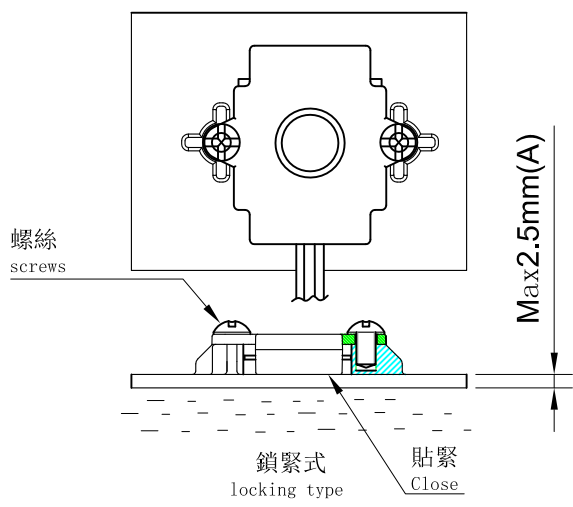

C

C

D

D

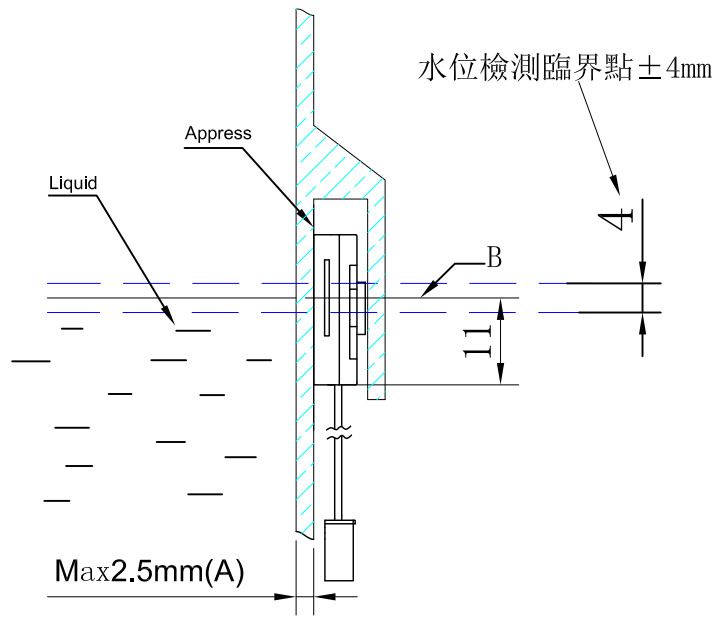

E

E

F

F

A: 水箱壁的厚度/A: Water tank thickness.

B: 水位檢測臨界點±4mm/B:Water level detecting critical point ±4mm.



注意: 1. 水箱的材料不應該是金屬/Notes: The material of water tank should not be metal.
 2. 应用环境: 传感器不可以放置于潮湿的环境中/Application environment: the sensor can not be placed in a humid environment

G

G

H

H

設計 Designer	Chen	材料 Material	*	單位 Unit	mm	 能點科技有限公司 EPT technology co., LTD			
檢查 Checked	Chen	表面處理 Finish	*	比例 Scale	*				
審批 Approver	Wei	數量 Quantity	*	篇幅 Size	A4	產品名 Product Name	D2CS-H	日期 Date	21-03-10
一般公差 Tolerances	0-10	±0.10		備註 Remarks	*	頁面內容 Page content	產品安裝示意圖	版本 REV	D
	10-35	±0.15				圖號 DWG NO.	*	頁數 Pages NO.	2/2
	35-70	±0.20							

1 2 3 4 5 6