



东莞市威力源电子科技有限公司

Customer's Name 客户名称:
印度 Macfos Pvt Ltd

File. No 文件编号: [WLY-501038/3.7/160](#)
Version 版本: A/0
Date 日期: [2022-9-8](#)

Product Specification 产品规格书

Type (类型): Rechargeable li-ion battery (可充电锂离子电池)

Model (型号): [501038/3.7V/160mAh](#)

Customer Approval (客户确认)		
Checked By/Date 审核/日期	Approved By/Date 批准/日期	Company Stamp (公司印章)

DONGGUAN WILIYOUNG ELECTRONICS CO., LTD (东莞市威力源电子科技有限公司)		
Prepared By/Date 编制/日期	Checked By/Date 审核/日期	Approved By/Date 批准/日期
伍喜艳 2022-9-8	罗龙敏 2022-9-8	

Address: No.5, Wenming 1 Street, Jinhe Community, Zhangmutou Town, Dongguan City, Guangdong Prov.
地址: 广东省东莞市樟木头镇金河社区文明一街 5 号
电话 (Tel): +86-0769-82932326
传真 (Fax): +86-0769-82932329

Product Summary 产品概要

— Standard 依据标准

— This product complies with National Standard GB31241-2014 《Safety requirements for lithium ion batteries and battery packs for portable electronic products》 of PRC.

— 本产品依据标准：中华人民共和国国家标准 GB31241-2014《便携式电子产品用锂离子电池和电池组安全要求》。

— Production description 产品描述

- Name 名称: **Li-ion Battery (锂离子电池)**
- Mode 型号: **501038/3.7V/160mAh**
- Cell 电芯: **501038/160mAh*1**
- Shelf period 保质期: 1 年
- Structure Drawing 电池结构图: (单位 mm, 正负公差 0.5mm)

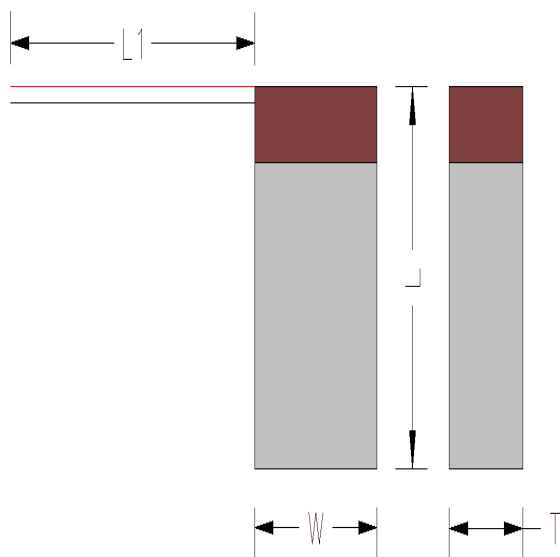

厚度 (T)	MAX:5.5
宽度 (W)	MAX:10.5
长度 (L)	MAX:40.5
外露线长 (L1)	50±5
喷码内容	-WLY 501038 +3.7V 160mAh 0.592Wh 日期 R-41174980



东莞市威力源电子科技有限公司

1、Scope and standard 适用范围及依据标准

1.1 Scope 适用范围

This specification is applied to battery manufactured by Dongguan Wiliyoung Electronics Co., Ltd.

本产品规格书适用于东莞市威力源电子科技有限公司提供的锂离子电池。

1.2 Standard 依据标准

This product complies with National Standard GB31241-2014 《Safety requirements for lithium ion batteries and battery packs for portable electronic products》 of PRC.

本产品依据标准：中华人民共和国国家标准 GB31241-2014 《便携式电子产品用锂离子电池和电池组安全要求》。

2、Specification 主要技术参数

NO 序号	Items 项目	Parameter 参数	Remarks 备注
2.1	Rated Capacity 标称容量	160mAh 150mAh (min)	Discharge:0.2C 放电 cut-off voltage:2.75V 截止电压
2.2	Energy 能量	0.592Wh	
2.3	Nominal Voltage 标称电压	3.7V	
2.4	Open Voltage 出厂电压	3.7~4.2V	
2.5	Load Voltage 负载电压	≥3.7V&≤4.2V	
2.6	Internal Impedance 内阻	≤300mΩ	AC 1KHz after standard charge 标准充电后 AC 1KHz 测试
2.7	Charge voltage 充电电压	4.2V	
2.8	Standard charge current 标准充电电流	80mA	0.5C CC (恒流) 充电至 4.2V, 再 CV(恒压 4.2V) 充电直至充电电流 ≤ 0.01C
2.9	Max charge current 最大充电电流	160mA	1.0C
2.10	Standard discharge current 标准放电电流	32mA	0.2C
2.11	Maximum continuous discharge current 最大持续放电电流	160mA	1.0C
2.12	Discharge cut-off voltage 放电截止电压	2.75V	过放保护电压 2.5±0.075V



东莞市威力源电子科技有限公司

2.13	Operating Temperature 工作温度	0°C~+45°C	Charge 充电
		-20°C~+60°C	Discharge 放电
2.14	Storage Temperature 贮存温度	-10°C~+45°C	Less than 1 month 小于一个月
		-10°C~+25°C	Less than 6 months 小于六个月
2.15	Weight 重量	About /g	

3.Battery configuration 电池组成 3.Battery configuration 电池组成

NO 序号	Item 项目	Criteria 标准	Remarks 备注
3.1	Cell 电芯	501038/160mAh	Li-ion
3.2	PCM 保护板	XBL-BQ-6535	单节锂电池保护板
3.3	Cable 线材	7 芯音响线红 55mm 黑 58mm 3302 无卤线	

4.Battery Performance Test 电池性能检查及测试

4.1 Appearance 外观和结构

There shall be no such defect as scratch, bur and other mechanical scratch, and the connector should be no rust dirt.

The structure and dimensions see attached drawing of the battery.

电池的表面应无明显的划痕毛刺及其其它机械划伤，外露的金属端子应无锈蚀污垢。结构尺寸见电池的外形尺寸图。（见附件：电池结构图）

4.2 Test Equipment 测试设备要求

(1) Dimension Measuring Instrument 尺寸测量设备

The dimension measurement shall be implemented by instruments with accuracy no less than 0.01mm.

测量尺寸的仪器的精度应不小于 0.01mm

(2) Voltmeter 电压表

Class with national standard or more sensitive class with inner impedance not less than 10 KΩ/V.

国家标准或更灵敏等级,内阻不小于 10 KΩ/V.

(3) Ammeter 电流表

Class with national standard or more sensitive class. Total external resistance including ammeter and wire is less than 0.01Ω.

国家标准或更灵敏等级，外部总内阻包括电流表和导线应小于 0.01Ω.

(4) Impedance Meter 内阻测试仪

Impedance shall be measured by a AC impedance method (AC 1kHz LCR meter).

内阻测试仪测试方法为交流阻抗法(AC 1kHz LCR).



东莞市威力源电子科技有限公司

4.3 Standard Test Condition 标准的测试条件

Test should be conducted with new batteries within one month after shipment from our factory and the cells shall not be cycled more than five times before the test. Unless otherwise defined, test and measurement shall be done under temperature of $20\pm 5^{\circ}\text{C}$ and relative humidity of 45~85%.

测试电池必须是本公司出厂时间不超过一个月的新电池，且电池未进行过五次以上充放电循环。除非其它特殊要求，本产品规格书规定的测试的环境条件为：温度 $20\pm 5^{\circ}\text{C}$ ，相对湿度 45%~85%。

4.4 Standard Charge 标准充电

0.5C=80mA Full charge condition: Constant current 0.5C, Constant voltage 4.2V for 3.5 hours in all at $20\pm 5^{\circ}\text{C}$.

0.5C=80mA 4.2V (CC-CV) 总充电时间不超过 3.5 小时，其中在 $20\pm 5^{\circ}\text{C}$ 环境下充电。

4.5 Common Performance 产品的常规性能

No	Items/项目	Testing method and determinant standard /测试方法和判定标准
1	Charge Performance 充电性能	The standard charge mode :under the temperature of $20\pm 5^{\circ}\text{C}$,charge the battery with the current of 0.5C until the voltage reaches up to 4.2V, then charge with constant voltage until the charge current $\leq 0.01\text{C}$, then stop charging. 标准充电模式：在 $20\pm 5^{\circ}\text{C}$ 条件下，电池用 0.5C 充电，当电池电压达到 4.2V 时改为恒压充电，直到充电电流小于或等于 0.01C 时停止充电。
2	Discharge Performance 放电性能	When connecting with load, the battery can supply power. Charge the battery with standard charge mode, then rest for 5min, then discharge with 0.2C until the voltage is 2.75V, and the discharge time is required $\geq 120\text{min}$. 电池外接负载能够供电。将电池按标准充电模式充好电后，开路搁置 5min，再以 0.2C 放电至 2.75V，要求放电时间 $\geq 120\text{min}$ 。
3	Cycle Performance 循环寿命	Charge the battery with standard charge mode, then stop charging, rest for 5min, then discharge with 0.5C to 2.75V. Cycle with the above mode, when the continuous discharge time $< 80\%$ stop cycling. The cycle life is required ≥ 300 times. 将电池按标准充电模式充好电后，静置 5min 后，0.5C 放电至 2.75V 的方式进行循环，当连续三次放电容量 $<$ 初始容量 80% 时寿命为终止，要求循环寿命 ≥ 300 次。



东莞市威力源电子科技有限公司

4.6 Safety Performance 产品可靠性

No	Items/项目	Test method and determinant standard /测试方法和判定标准
1	Overcharge Protection Characteristics 过充电保护性能	After full-charging the battery with 0.5C and set 1.5 times of the nominal voltage and current as constant current and voltage supply, then load it to the battery for 8h. It is required the battery should be no leakage, deformation, smoking and explosion during the test processes. 电池按 0.5C 充满电后, 再将恒流恒压源设定为 1.5 倍标称电压、电流, 然后加载于电池上 8h, 要求试验过程中电池不漏液、变形、冒烟和爆炸。
2	Over-discharge Protection Characteristics 过放电保护性能	Under the temperature of 20±5°C, after discharging the battery with 0.2C to 2.75V, then connect the load with 30Ω and discharge for 24h. It is required the battery should be no leakage, fire, smoking and explosion during the test processes. 在 20±5°C 条件下, 电池按 0.2C 放电至 2.75V 后, 外接 30Ω 负载再放电 24h, 要求实验过程中电池不漏液、起火、冒烟和爆炸。
3	Short-circuit Protection Characteristics 短路保护性能	Under the temperature of 20±5°C, after full-charging the battery with 0.5C, then make the battery's anode and cathode short-circuit for 1h (the connecting resistance is smaller than 100mΩ), then cut the anode and cathode, and there should be no leakage, deformation, smoking and explosion during the test processes. 在 20±5°C 条件下, 电池按 0.5C 充满电后, 将电池正负极短路 (外接电阻小于 100mΩ) 持续 1h, 再将电池正负极断开, 试验过程中电池不漏液、变形、冒烟和爆炸。

4.7 Rest Period 搁置时间

Unless otherwise defined, 5 min, rest period after charge;

如无特殊要求, 电池充放电间隔为 5min。

5、 Storage and Others 贮存及其它事项

5.1 Long Time Storage 长期贮存

If stored for a long time (exceed three months), the cell should be stored in dry and cooling place. The cell's storage voltage should be 3.7V~4.0V and the cell is to be stored in a condition as appendix No. 4

长期贮存的电池 (超过 3 个月) 须置于干燥、凉爽处。贮存电压为 3.7V~4.0V 且贮存环境要求如附录 4

5.2 Others 其它事项

Any matters that this specification does not cover should be conferred between the customer and WILIYOUNG.

任何本说明书中未提及的事项，须经双方协商确定。

6、Protection Circuit 保护电路

6.1 Circuit Diagram 电路原理图

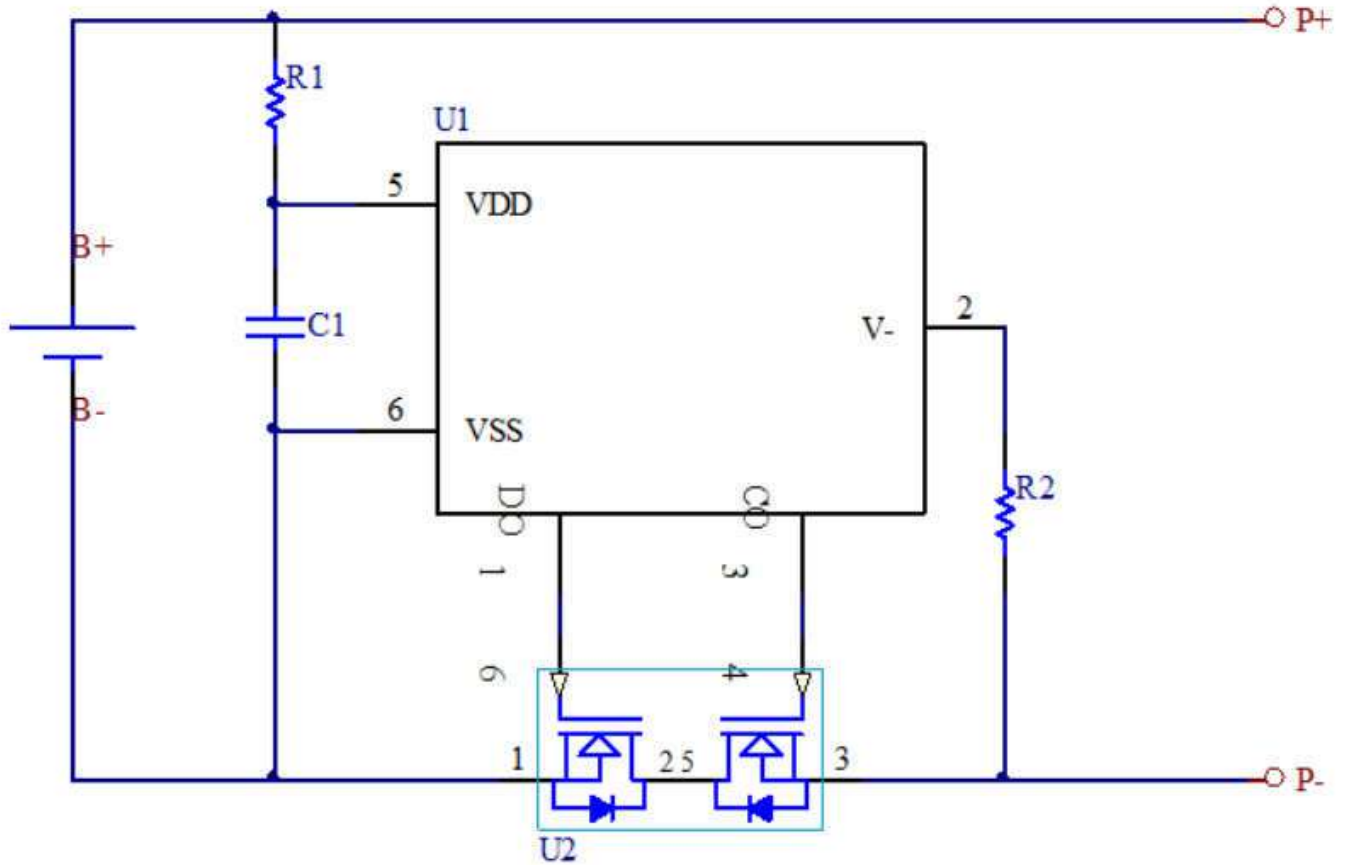



东莞市威力源电子科技有限公司

6.2 PCM parameter PCM 参数

保护IC:	FHDW01	参数值 parameter value			
Protection IC:		常温25℃ General temperature 25℃			
项目 item	最小值 Min.	典型值 Type value	最大值 Max.	单位 Unit	
过充保护电压 Over charge protection voltage	4.250	4.300	4.350	V	
过充保护恢复电压 Over charge release voltage	4.050	4.100	4.150	V	
过放保护电压 Over discharge protection voltage	2.425	2.500	2.575	V	
过放保护恢复电压 Over discharge release voltage	2.825	2.900	2.975	V	
放电过流检测电压 Over current detection voltage	0.130	0.150	0.170	V	
充电过流检测电压 Charging Overcurrent Detection Voltage	/	/	/	V	
放电过流保护电流 Over current protection current	2	3.5	5	A	
充电过流保护电流 Charging Overcurrent Protection Current	/	/	/	A	
过充保护延迟时间 Over charge protection delay time	77	110	143	ms	
过放保护延迟时间 Over discharge protection delay time	38.5	55	71.5	ms	
放电过流保护延迟时间 Over current protection delay time	4.9	7	9.1	ms	
充电过流保护延迟时间 Charging Overcurrent Protection Delay Time	/	/	/	ms	
短路保护延迟时间 Short protection delay time	200	400	600	us	
正常状态下静态电流 Current consumption (Operation)		2.0	6.0	uA	
过放状态下静态电流 Current consumption (Power down)		0.7	1.0	uA	
导通内阻 Impedance		45	60	mΩ	
输入电压 Input voltage			5.0	V	
最大持续放电电流 Max continuous discharge current			1	A	
最大持续充电电流 Maximum Continuous Charging Current			1	A	
工作温度 Operating temperature	-20		+55	℃	
推荐存储条件 Recommendatory storage condition	Temperature range: -5~+35℃ Humidity: 0%~75%RH				
其它功能 Other functions	过放自恢复				
0V电池充电功能 0V battery charge function	允许Available				

7、PCB line drawing and parts name specification

PCB 焊盘线路图及零部件名称规格表

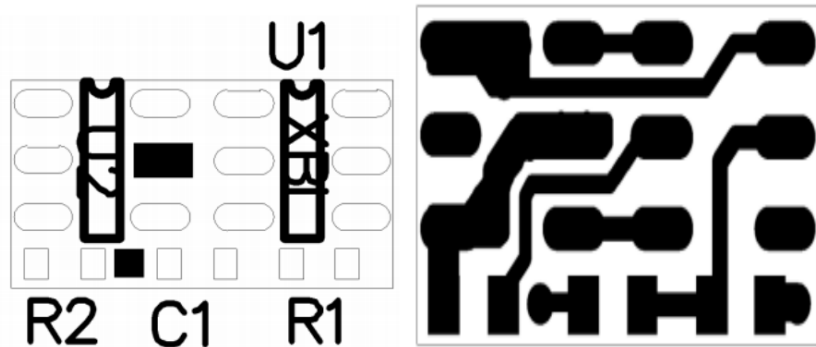

物料名称	品牌	型号/规格	封装	元件编号	数量
贴片电容		0.1 μ F/+80%-20%	0402	C1	1
贴片电阻		100 Ω / \pm 5%	0402	R1	1
贴片电阻		1K Ω / \pm 5%	0402	R2	1
贴片保护IC		FHDW01	SOT-23-6	U1	1
贴片MOSFET		FHS205A	SOT-23-6	U2	1
PCB		XBL-BQ-6535双面板/喷锡	绿油/白字	6.5*3.5*0.6mm	1



东莞市威力源电子科技有限公司

Appendix 附录

Handling Precautions and Guideline For LIP (Lithium-Ion) Rechargeable Batteries

锂离子充电电池操作指示及注意事项

Preface 前言

This document of 'Handling Precautions and Guideline LI Rechargeable Batteries' shall be applied to the battery cells manufactured by DONGGUAN WILYOUNG ELECTRONICS CO., LTD
本档“锂离子可充电电池操作指示及注意事项”仅适用于东莞市威力源电子科技有限公司生产的电池。

Note (1) : 声明一

The customer is requested to contact DONGGUAN WILYOUNG ELECTRONICS CO., LTD in advance, if and when the customer needs other applications or operating conditions than those described in this document. Additional experimentation may be required to verify performance and safety under such conditions.

客户若需要将电池用于超出本规格书规定以外的设备，或在本规格书规定以外的使用条件下使用电池，应事先联系东莞市威力源电子科技有限公司，因为需要进行特定的实验测试以核实电池在该使用条件下的性能及安全性。

Note (2) : 声明二

DONGGUAN WILYOUNG ELECTRONICS CO., LTD will take no responsibility for any accident when the cell is used under other conditions than those described in this Document.

对于在超出本规格书规定以外的条件下使用电池而造成的任何意外事故，东莞市威力源电子科技有限公司概不负责。

Note (3): 声明三

DONGGUAN WILYOUNG ELECTRONICS CO., LTD will inform, in a written form, the customer of improvement(s) regarding proper use and handling of the cell, if it is deemed necessary.

如有必要，东莞市威力源电子科技有限公司会以书面形式告知客户有关正确操作使用电池的改进措施。

1、Charging 充电

1.1 Charging current 充电电流

Charging current should be less than maximum charge current specified in the Product Specification. Charging with higher current than recommended value may cause damage to cell electrical, mechanical, and safety performance and could lead to heat generation or leakage.

充电电流不得超过本规格书中规定的最大充电电流。使用高于推荐值电流充电将可能引起电池的充放电性能、机械性能和安全性能的问题，并可能会导致发热或泄漏。

1.2 Charging voltage 充电电压

Charging shall be done by voltage less than that specified in the Product Specification (4.2V/battery). Charging beyond 4.3V, which is the absolute maximum voltage, must be strictly prohibited. The charger shall be designed to comply with this condition.



东莞市威力源电子科技有限公司

充电电压不得超过本规格书中规定的额定电压（4.2V/电池）。4.3V 为充电电压最高极限，充电器的设计应满足此条件。

It is very dangerous that charging with higher voltage than maximum voltage may cause damage to the cell electrical, mechanical safety performance and could lead to heat generation or leakage.

电池电压高于额定电压值时，将可能引起电池的充放电性能、机械性能和安全性能的问题，可能会导致发热或泄漏。

1.3 Charging temperature 充电温度

The cell shall be charged within 0°C~45°C range in the Product Specification.

电池必须在 0°C~45°C 的环境温度范围内进行充电。

1.4 Prohibition of reverse charging 禁止反向充电

Reverse charging is prohibited. The cell shall be connected correctly. The polarity has to be confirmed before wiring. In case of the cell is connected improperly, the cell cannot be charged. Simultaneously, the reverse charging may cause damaging to the cell which may lead to degradation of cell performance and damage the cell safety, and could cause heat generation or leakage.

正确连接电池的正负极，严禁反向充电。若电池正负极接反，将无法对电池进行充电。同时，反向充电会降低电池的充放电性能、安全性，并会导致发热、泄漏。

2、Discharging 放电

2.1 Discharging current 放电电流

The cell shall be discharged at less than the maximum discharge current specified in the Product Specification. High discharging current may reduce the discharging capacity significantly or cause over-heat.

放电电流不得超过本规格书规定的最大放电电流，大电流放电会导致电芯容量剧减并导致过热。

2.2 Discharging temperature 放电温度

The cell shall be discharged within -5°C~45 °C range specified in the Product Specification.

电池必须在 -5°C~45°C 的环境温度范围内进行放电。

2.3 Over-discharging 过放电

It should be noted that the cell would be at an over-discharged state by its self-discharge characteristics in case the cell is not used for long time. In order to prevent over-discharging, the cell shall be charged periodically to maintain between 3.7V~4.0V.

需要注意的是，在电池长期未使用期间，它可能会因其自放电特性而处于某种过放电状态。为防止过放电的发生，电池应定期充电，将其电压维持在 3.7V~4.0V 之间。

Over-discharging may causes loss of cell performance, characteristics, or battery functions



东莞市威力源电子科技有限公司

过放电会导致电芯性能、电池功能的丧失。

The charger shall be equipped with a device to prevent further discharging exceeding a cut-off voltage specified in the Product Specification. Also the charger shall be equipped with a device to control the recharging procedures as follows: The cell battery pack shall start with a low current (0.01C) for 15 - 30 minutes, i.e. pre-charging, before rapid charging starts. The rapid charging shall be started after the (individual) cell voltage has been reached above 2.75V within 15 - 30 minutes that can be determined with the use of an appropriate timer for pre-charging. In case the (individual) cell voltage does not rise to 2.75V within the pre-charging time, then the charger shall have functions to stop further charging and display the cell/pack is at abnormal state.

充电器应有装置来防止电池放电至低于本规格书规定的截止电压。此外，充电器还应有装置以防止重复充电，步骤如下：电池在快速充电之前，应先以一小电流（0.01C）预充电 15~30 分钟，以使电池的电压达到 2.75V 以上，再进行快速充电。可用一计时器来实现该预充电步骤。如果在预充电规定时间内，电池的电压仍未升到 2.75V 以上，充电器应能够停止下一步快速充电，并显示该电芯/电池正处于非正常状态。

3. Protection Circuit Module 保护电路模块

The cell/battery pack shall be with a PCM that can protect cell/battery pack properly. PCM shall have functions of (1) overcharging prevention, (2) over-discharging prevention, (3) over current prevention to maintain safety and Prevent significant deterioration of cell performance. The over current can occur by external short circuit

电芯/电池包装应配有 PCM 板以正确保护电芯/电池。PCM 板应具有以下功能以保证安全并防止损坏电池性能：

(1) 过充保护功能 (2) 过放保护功能 (3) 过流保护功能。

3.1 overcharging protection: 过充保护电压

Overcharging protection function shall stop charging if any one of the cells of the battery pack reaches 4.3V; 当电池中任一电芯的电压达到 4.3V 时，过充电保护功能应立即启动并停止充电。

3.2 over-discharging protection: 过放电保护

Over-discharging prevention function shall work to avoid further drop in cell voltage of 2.5V

Or less per cell in any cell of the battery pack. It is recommended that the dissipation current of PCM

Shall be minimized to 0.5uA or less with the over-discharging prevention, the protection function shall monitor each bank of the battery pack and control the current all the time

当电池中任一电芯的电压降至 2.5V 保护功能应起保护作用以避免电芯的深度放电。推荐 PCM 板的静态电流小于 0.5uA，并具有过放保护功能。该保护功能应实时监控所有电芯；

4、Storage 贮存

The battery shall be storied within -5°C~ 35°C range environmental condition.

电池储存温度必须在 -5°C~ 35°C 的范围内。

If the battery has to be storied for a long time (Over 3 months), the environmental condition should be:

Temperature: 23±5°C, Humidity: 65±20%RH

长期存储电池（超过 3 个月）须置于温度为 23±5°C、湿度为 65±20%RH 的环境中。

The voltage for a long time storage shall be 3.7V~4.0V range.

贮存电压为 3.7V~4.0V 。



东莞市威力源电子科技有限公司

5、Handling Instructions 电池的注意事项

Read and observe the following warnings and precautions to ensure correct and safe use of Li-ion batteries.

认真阅读下面的注意事项，确保正确使用锂离子电池。东莞市威力源电子科技有限公司对违反下述注意事项而产生的任何问题不予负责。

Danger! **危 险!**

- Do not immerse the battery in water or allow it to get wet.
- 勿将电池投入水中或将其弄湿！
- Do not use or store the battery near sources of heat such as a fire or heater.
- 禁止在火源或极热条件下给电池充电！勿在热源（如火或加热器）附近使用或贮存电池！如果电池泄漏或发出异味，应立即将其从接近明火处移开；
- Do not use any chargers other than those recommended.
- 请使用专用充电器！
- Do not reverse the positive (+) and negative (-) terminals.
- 勿将正负极接反！
- Do not connect the battery directly to wall outlets or car cigarette-lighter sockets.
- 勿将电池直接连接到墙上插座或车载点烟式插座上！
- Do not put the battery into a fire or apply direct heat to it.
- 勿将电池投入火中或给电池加热！
- Do not short-circuit the battery by connecting wires or other metal objects to the positive (+) and negative (-) terminals.
- 禁止用导线或其它金属物体将电池正负极短路，禁止将电池与项链、发夹或其它金属物体一起运输或贮存！
- Do not pierce the battery casing with a nail or other sharp object, break it open with a hammer, or step on it.
- 禁止用钉子或其它尖锐物体刺穿电池壳体，禁止锤击或脚踏电池！
- Do not strike, throw or subject the battery to sever physical shock.
- 禁止撞击、投掷或者使电池受到机械震动
- Do not directly solder the battery terminals.
- 禁止直接焊接电池端子！
- Do not attempt to disassemble or modify the battery in any way.
- 禁止以任何方式分解电池！
- Do not place the battery in a microwave oven or pressurized container.
- 禁止将电池置入微波炉或压力容器中！
- Do not use the battery in combination with primary batteries (such as dry-cell batteries) or batteries of different Capacity type or brand.
- 禁止与一次电池（如干电池）或不同容量、型号、品种电池组合使用！
- Do not use the battery if it gives off an odor, generates heat, becomes discolored or deformed, or appears abnormal in any way. If the battery is in use or being recharged, remove it from the device or charger immediately and discontinue use.
- 如果电池发出异味、发热、变形、变色或出现其它任何异常现象时不得使用；如果电池正在使用或充电，应立即



东莞市威力源电子科技有限公司

即从用电器中或充电器上取出并停止使用！

Caution! 注意！

Do not use or store the battery where is exposed to extremely hot, such as under window of a car in direct sunlight in a hot day. Otherwise, the battery may be overheated. This can also reduce battery performance and/or shorten service life.

不要使用处于极热环境中的电池，如阳光直射或热天的车内。否则，电池会过热，可能着火（点燃），这样就会影响电池的性能、缩短电池的使用寿命。

If the battery leaks and electrolyte gets in your eyes, do not rub them. Instead, rinse them with clean running water and immediately seek medical attention. If left as is, electrolyte can cause eye injury.

如果电池漏液后电解液进入眼睛，不要擦拭，应用水冲洗，立即寻求医疗救助。如不及时处理，眼睛将会受到伤害。

Use the battery only under the following environmental conditions. Failure to do so can result in reduced performance or a shorten service life. Recharging the battery outside of these temperatures can cause the battery to overheat, explode or catch fire.

只能在下述条件下使用电池，否则将会降低电池的性能或缩短电池的使用寿命。

Operating environment:

工作环境

When charging the battery: 0°C~45°C

充电: 0°C~45°C

When discharging the battery: -5°C~45°C

放电: -5°C~45°C

When stored up to 30 days: -5°C~35°C

储存 30 天: -5°C~35°C

When stored up to 90 days: -5°C~25°C

储存 90 天: -5°C~25°C

6.Amendment of this Specification 产品规格书的修订

This specification is subject to change with prior notice.

本公司有权对本产品规格书进行修订，在对产品规格书修订后东莞市威力源电子科技有限公司将会通知客户。